

Type 250



TECHNICAL DATA

Preset Revolution, Length Measuring or Stroke Counter

- 5-digit display
- Large 6.5 mm digits
- Button reset

Display	5-digit display
Digit height	6.5 mm
Electrical connection	rear strain relief 4-wire cable, approx. 30 cm long
Protection class	IP 40, connections IP 00 (EN 60529)
General design	DIN EN 61010-1 Protection according to class I Contamination level 2 Over voltage category II
Base plate	burnished sheet steel
Case	die-cast metal, black varnish
Cap	plastic (ABS), grey
Weight	approx. 800 g
Counting mode	- + subtracting in specified direction of rotation, adding in reverse, stroke counter - subtracting in specified direction of rotation
Transmission ratio	see "Order information"
Speed	10000 increments/min, stroke counter 800 strokes/min
Actuating angle	min. 38°, max. 55° (stroke counter only)
Torque	1.2 Ncm, stroke counter 8.0 Ncm
Reset	button reset, secured against accidental operation

Output	
Signal duration	on transition from 00000 to 99999 until reset
Contact type	single-pole changeover contact
Switching voltage	max. 125 VDC/250 VAC
Switching current	max. 20 VA/0.3 A
⚠	Don't push the reset pushbutton during the process

DIMENSIONS

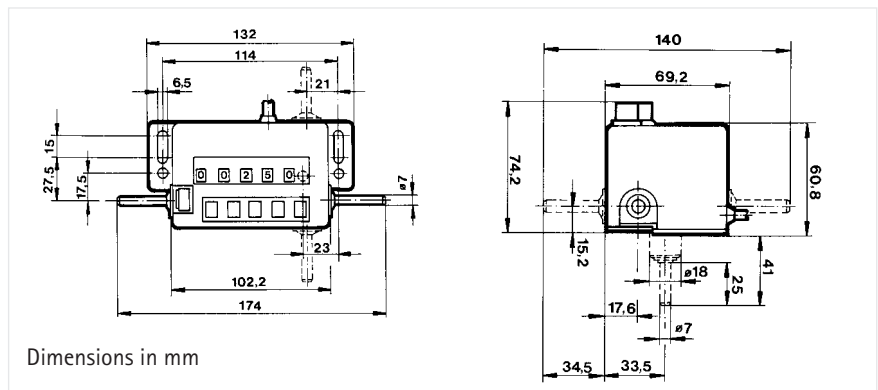

CONNECTION DIAGRAM

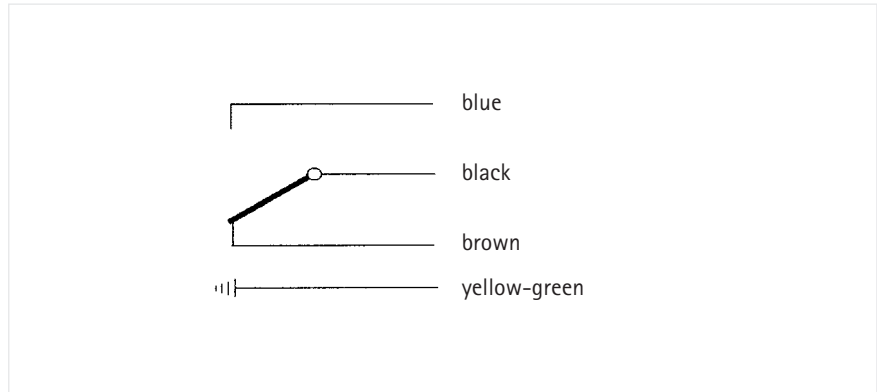

ORDER INFORMATION

Revolution counter

Length counter

Stroke counter

Accessories

Actuation	Transmis- sion ratio	Display	Unit	Bz	Bw	U	G
-----------	-------------------------	---------	------	----	----	---	---

	1:1	99999		0 250 001	0 250 002	-	-
	1:1	99999		-	-	0 250 101	0 250 102
	1:1	99999		-	-	0 250 201	0 250 202
	5:1	99999	m	0 250 013	0 250 014	-	-
	2:1	99999	m	0 250 019	0 250 020	-	-
	1:5	9999.9	m/dm	0 250 023	0 250 024	-	-
	5:1	99999	m	-	-	0 250 105	0 250 106
	1:1	99999		0 250 301	0 250 302	-	-

Stroke lever Ordering code 0 600 005

For other stroke levers, measuring wheels and installation frames see "Accessories"